

# Linear Regulated DC Power Supplies

## International Series: BVA

- Dual output
- Worldwide field selectable 100/117/220/230-240VAC input
- Rated full load at 50°C
- Overload and short circuit protection
- Remote sense compensates for line drop and assures voltage the load
- Reverse Polarity protection
- Open sense lead protection
- Overvoltage Protection (OVP) standard on 5V main outputs
- Up to 600 watts regulated output
- Made in the U.S.A.
- 2 year warranty



### Agency Approvals:

- UL File # E181899
- CB Scheme, File #MC3535
- CSA C22.2 No. 950, UL File #E181899



### The International Series BVA

The BVA series is the premium grade, open frame line of linear DC power supplies. Designed to operate over a wide range of AC power sources found worldwide, the BVA series is especially suited for OEM applications where cost is a significant factor. The field selectable universal input (100/117/220/230-240VAC) reduces your inventory cost by allowing to use just one standard model regardless of destination.

### Value Added Services

PowerVolt offers a wide variety of value added services and design features to meet your application requirements. The first and foremost service we offer is our flexibility to design custom units for your application. Other features include , but are not limited to, terminal blocks, mounting spacers, fuse and fuse holders, line cords etc. Please contact your local factory representative, distributor or factory direct for quotations.

### Specifications

**AC Input:** Field selectable taps for 100/117/220/230-240 VAC  $\pm 10\%$ ; 47-63Hz. See chassis ID label for jumper and line fusing requirements. For 50Hz operation derate output by 10%

**DC Output:** See selection guide for voltage/current ratings. The output is floating; either positive or negative terminal can be grounded. Output adjustment range is  $\pm 10\%$ , expect variable 10-18V outputs.

**Line Regulation:**  $\pm 0.05\%$  for 10% line change

**Load Regulation:**  $\pm 0.05\%$  for 50% load change

**Thermal Regulation:**  $\pm 0.02\%$  per °C maximum,  $\pm 0.005\%$  per °C typical

**Output Ripple:** 2mV RMS maximum, 3mV P-P

**Dynamic Response:** 30 microseconds for 50% load change

**Stability:**  $\pm 0.03\%$  for 24 hour period after 1 hour warm up

**Short Circuit and Overload Protection:** Foldback current limiting, set at 120% of nominal

**Overvoltage Protection:** Crowbar overvoltage protection is standard on all 5VDC main outputs and is factory set at 6.2V $\pm 0.4$ V (fixed). Optional universal OVP module adjustable from 4.5 to 36V is available for other models.

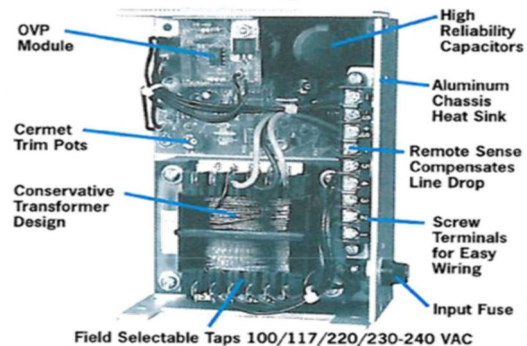

**Remote Sensing:** Standard on all outputs above 30 watts. Remote sense will compensate for a cable drop of 0.25V. Protected against open or shorted sense leads. Twisted pair sense leads are recommended.

**Efficiency:** 5V units: 45%; 12 and 15V units: 55%; 24V and higher units: 60%

**Operating Temperature:** 0°C to 50°C full rated load, derate linearly to 40% at 70°C. See derating chart.

**Storage Temperature:** -55°C to +85°C

**Vibration:** Per MIL-STD-810B, Method 514, Procedure I, Curve AB (to 50 Hz) **Shock:** Per MIL-STD-810B, Method 516, Procedure V

**Safety Standards:** • UL 60950-1, Second Edition • CSA C22.2 No. 60950 • CE Marked • CB Scheme

**Finish:** Clear aluminum chassis. Also serves as heat sink.

**Mounting:** Units can be mounted on several surfaces. Mounting holes will accept press fit #6-32 threaded fasteners. For efficient cooling, allow unrestricted air flow. Forced air cooling may be recommended.

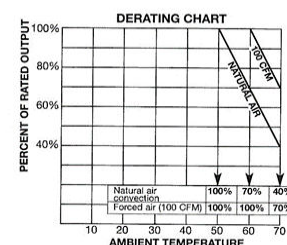

# Linear Regulated DC Power Supplies: Operation and Application Notes

## AC Input Wiring and Fusing

The universal transformer allows four input voltage ranges - 100/117/220/230-240 VAC  $\pm 10\%$ . All standard models are factory wired for 117V operation. Before operation at a specific line voltage, the proper input jumpers must be installed. Adequate input fusing is also recommended. For jumper scheme and fusing requirements, refer to the unit ID label or the table below.

Input (VAC)	100	117	220	230-240
Jumper	1 - 2 3 - 4	1 - 2 3 - 4	2 - 3	2 - 3
Apply AC	1 - 5	1 - 4	1 - 5	1 - 4
Fuse	See unit ID label. Recommended 150% of output current.			

**Jumping Example:** For operation at 117VAC, jumper 1-2 and 3-4; and apply AC input to 1 - 4.

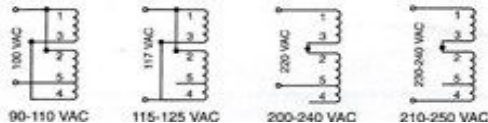

## DC OUTPUT WIRING

### Local Sense

When load leads are not too long and remote regulation is not required, simply connect the load to the output terminals marked +Vo or +Out and -Vo or -Out. **Load leads must never be connected to the sense terminals.** Open sense lead protection is built-in and strapping the sense leads to the output leads is not needed, but is recommended.

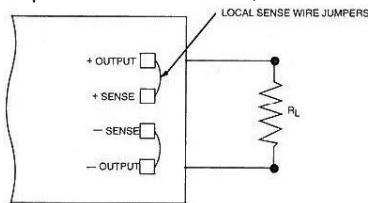

### Remote Sense

All models above 30 watts are provided with remote sense feature to compensate the load line drop and to permit a remote point of regulation. The figure below shows proper wiring for a power supply with remote sensing.

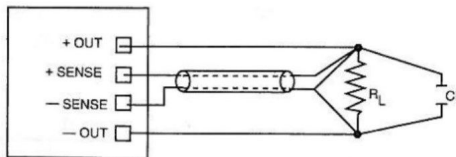

The remote sense can compensate a line drop of up to 0.25V. The load leads must be sized so that the line drop does not exceed 0.25V - the lesser the better. To provide noise immunity, it is recommended to use twisted pair or shielded pair for sense leads. A small AC decoupling capacitor (0.1 to 10 microfarad) across the sense terminals will also enhance the noise immunity. In some applications, the power supply output tends to oscillate due to the phase shift caused by the line resistance and inductance. The addition of capacitor C1 will reduce output impedance and provide stability. The recommended value of C1 is 100 microfarads per ampere or 50 microfarads per foot of lead wire.

## Grounding

The grounding, if not done right, can have a significant effect on the overall system performance. A single point grounding the system should be employed, whenever possible, to eliminate ground loops and to improve regulation.

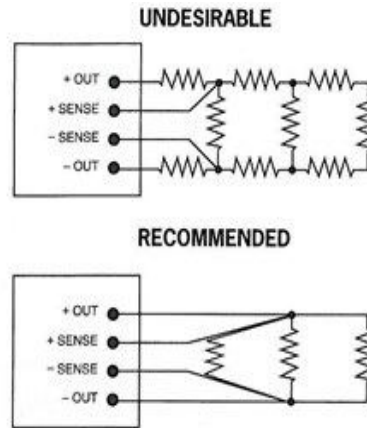

## Thermal Considerations

In normal operation the chassis gets hot due to the heat generated in the regulator. An unrestricted mounting area is recommended. Moving air is desirable in confined areas. The chassis may be mounted on the other heat dissipating surfaces to improve cooling.

## Overvoltage Protection (OVP) Adjustment

The overvoltage is fixed on +5V outputs and is factory set at 6.2  $\pm 0.4$ V. On all other outputs, a separate universal OVP module should be used. Single output units normally have their OVP adjusted at 1 to 2 volts or 10 to 20% (whichever is greater) above the nominal output voltage. For dual output units, the criteria applies above the sum of the two voltages. Adjust OVP as follows:

- Adjust OVP adj. potentiometer fully clockwise
  - Apply AC input voltage
  - Adjust output voltage to the desired overvoltage trip point
  - Turn the OVP adj. potentiometer counterclockwise until output voltage is crowbarred to approximately 1 volt
  - Switch the AC input off and adjust the output voltage down.
- Reapply AC input voltage and adjust the output up to verify the set point.

## Overload Adjustment

The overload is factory set at 110 to 120% and should not require any adjustment. If this has been changed or require recalibration, it can be accomplished as follows:

- Adjust OL adj. potentiometer fully clockwise
- Apply AC input voltage
- Adjust output to the lowest voltage of the specified voltage range
- Adjust the load current to 110 to 120% of rated output current
- Slowly turn the OL adj. potentiometer counterclockwise until the voltage starts decreasing

**Single Output, Linear**  
**Series: BVA - Single Output**



**Partial Selection Guide**

Dual Output Models				
Voltage	Model	Case	Output	
			#1	#2
±5 Volts	BVA-5AD1.5-OVP	AD	5V @ 1.5A	-5V @ 1.5A
	BVA-5BD3-OVP	BD	5V @ 3A	-5V @ 3A
	BVA5CD6-OVP	CD	5V @ 6A	-5V @ 6A
±12 Volts	BVA-12AA0.4	AA	12V @ 0.4A	-12V @ 0.4A
±15 Volts	BVA-15AA0.4	AA	15V @ 0.4A	-15V @ 0.4A
±12 to 15 Volts	BVA-12AD1.0	AD	12V @ 1A, or	-12V @ 1A, or
			15V @ 0.8A	-15V @ 0.8A, or -5V @ 0.4A
	BVA-12BD1.7	BD	12V @ 1.7A, or	-12V @ 1.7A, or
			15V @ 1.5A	-15V @ 1.5A, or -5V @ 0.7A
	BVA-CD3.4	CD	12V @ 3.4A, or	-12V @ 3.4A, or
			15V @ 3A	-15V @ 3A
	BVA-12ED5	ED	12V @ 5A, or	-12V @ 5A, or
			15V @ 5A	-15V @ 5A
<b>Ask for specials. Custom variations quoted and shipped promptly.</b>				

**Options:**

**Screw Terminals (T):** Solder terminals standard. Add "T" for screw terminals, 20A/300V

**Overvoltage Protection (OVP):** OVP is standard on all 5V main outputs. Add "OVP" to part number for individual OVP module on other

**Mounting Spacers (S):** For mounting spacers on any one surface add 'S' to part number. Not available on FS and GS case sizes.

**Input Fuse (F):** For input fuse and fuse holder add "F" to part number.

**Line Cord (C):** For input line cord add "C" to part number.

**Surge Absorber (M):** Input MOV 150V for line voltage of 100-117VAC; and 320V for line voltage of 220-240VAC.

**AS CASE / AA CASE**

**WEIGHT: 2 LBS.**

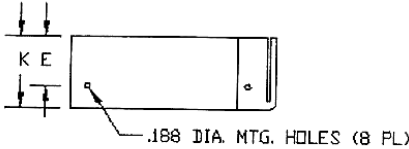
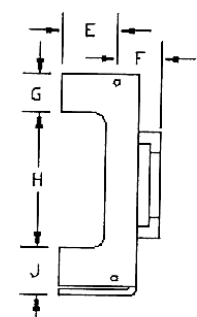
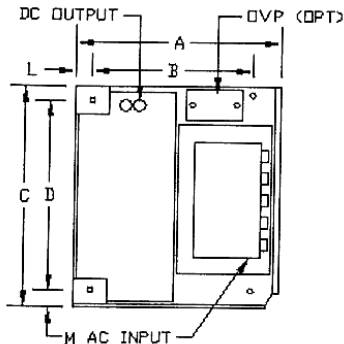

	INCH	mm
A	4.87	123.70
B	4.125	104.80
C	4.00	101.60
D	3.375	86.73
E	0.87	22.10
F	0.450	11.43
G	0.794	20.20
H	2.601	66.07
J	0.605	15.37
K	1.62	41.15
L	0.250	6.35
M	0.375	9.53

OVERALL SIZE  
4.87" x 4.00" x 2.07"

**AD CASE  
AT CASE**

**WEIGHT: 2 LBS.**

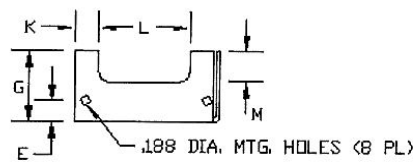
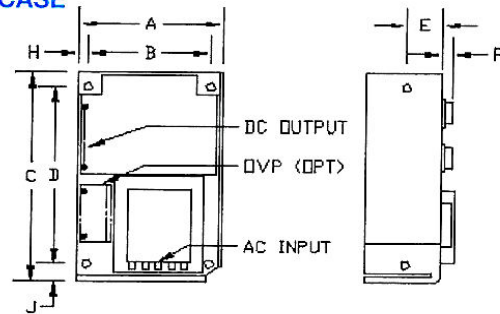

	INCH	mm
A	4.00	101.60
B	3.375	85.73
C	6.50	165.10
D	5.750	146.05
E	0.75	19.05
F	0.450	11.43
G	1.62	41.15
H	0.25	6.35
J	0.50	12.70
K	0.955	24.26
L	2.37	60.20
M	0.57	14.48

OVERALL SIZE  
6.50" x 4.00" x 2.07"

**BD CASE**

**WEIGHT: 4 LBS.**

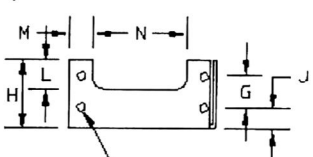
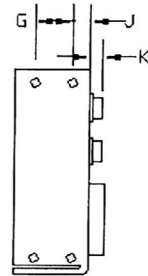
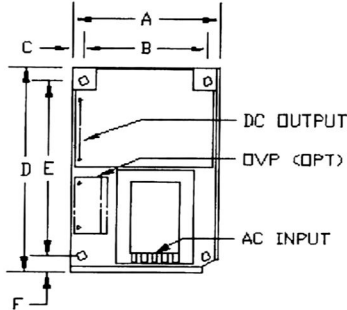

	INCH	mm
A	4.87	123.70
B	4.125	104.78
C	0.25	6.35
D	7.00	177.80
E	6.250	158.75
F	0.50	12.70
G	1.250	31.75
H	2.50	63.50
J	0.75	19.05
K	0.450	11.43
L	0.665	16.89
M	1.025	26.03
N	2.85	72.39

OVERALL SIZE  
7.00" x 4.87" x 2.95"

**CD CASE**

**WEIGHT: 7 LBS.**

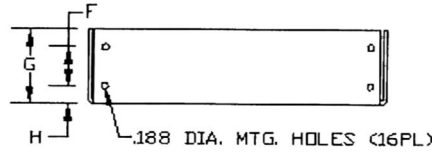
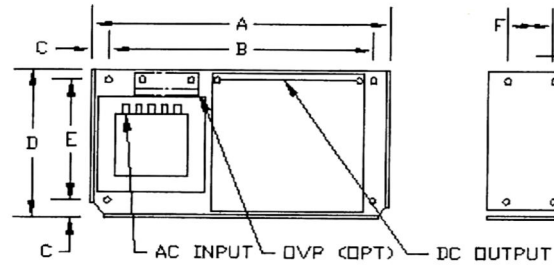

	INCH	mm
A	9.38	238.25
B	8.375	212.73
C	0.50	12.70
D	4.87	123.70
E	4.125	104.78
F	1.250	31.75
G	2.75	69.85
H	0.75	19.05
J	0.525	13.34

OVERALL SIZE  
9.38" x 4.87" x 3.28"

**ED CASE**

**WEIGHT: 10 LBS.**

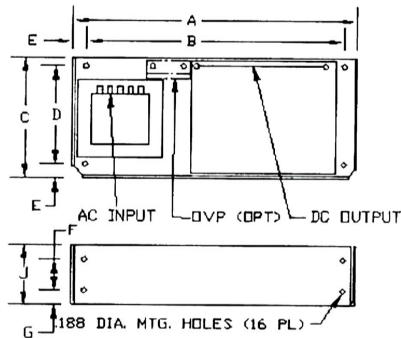

	INCH	mm
A	14.00	355.60
B	13.000	330.20
C	4.87	123.70
D	4.125	104.78
E	0.50	12.70
F	1.250	31.75
G	0.75	19.05
H	0.650	16.51
J	2.75	69.85

OVERALL SIZE  
14.00" x 4.87" x 3.40"